

SIDE MOUNT SPIGOT
FOR USE WITH STANDARD RANGE SHS POLES

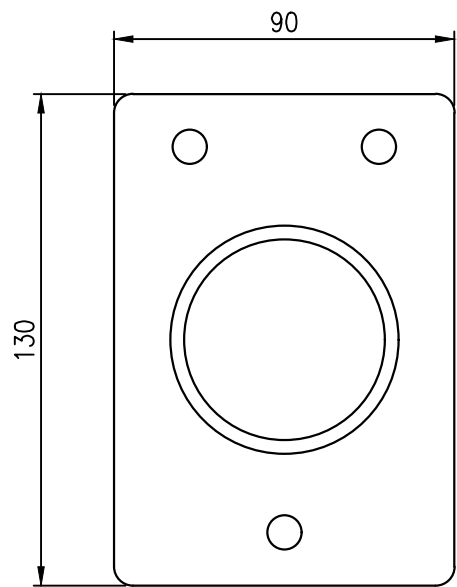

ELEVATION
SCALE 1:2

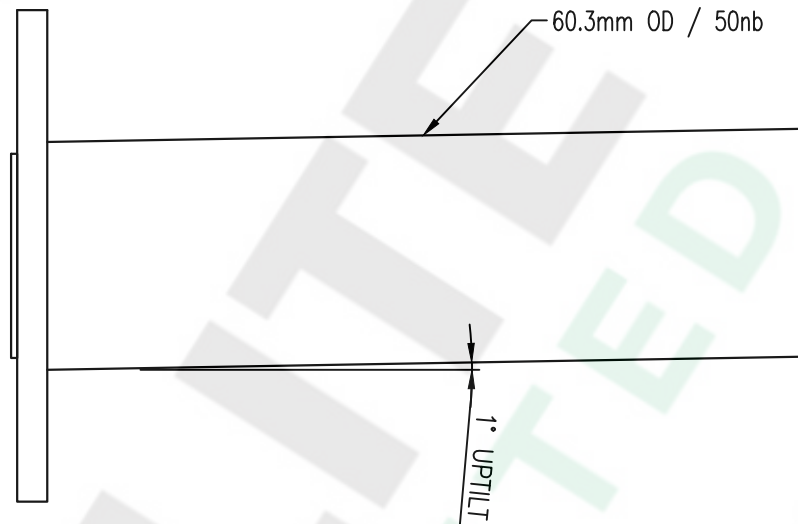

SIDE VIEW
SCALE 1:2

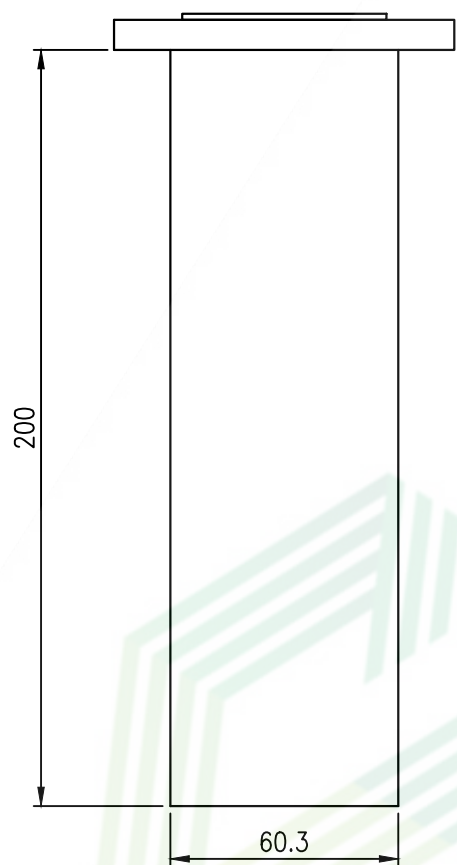

PLAN
SCALE 1:2

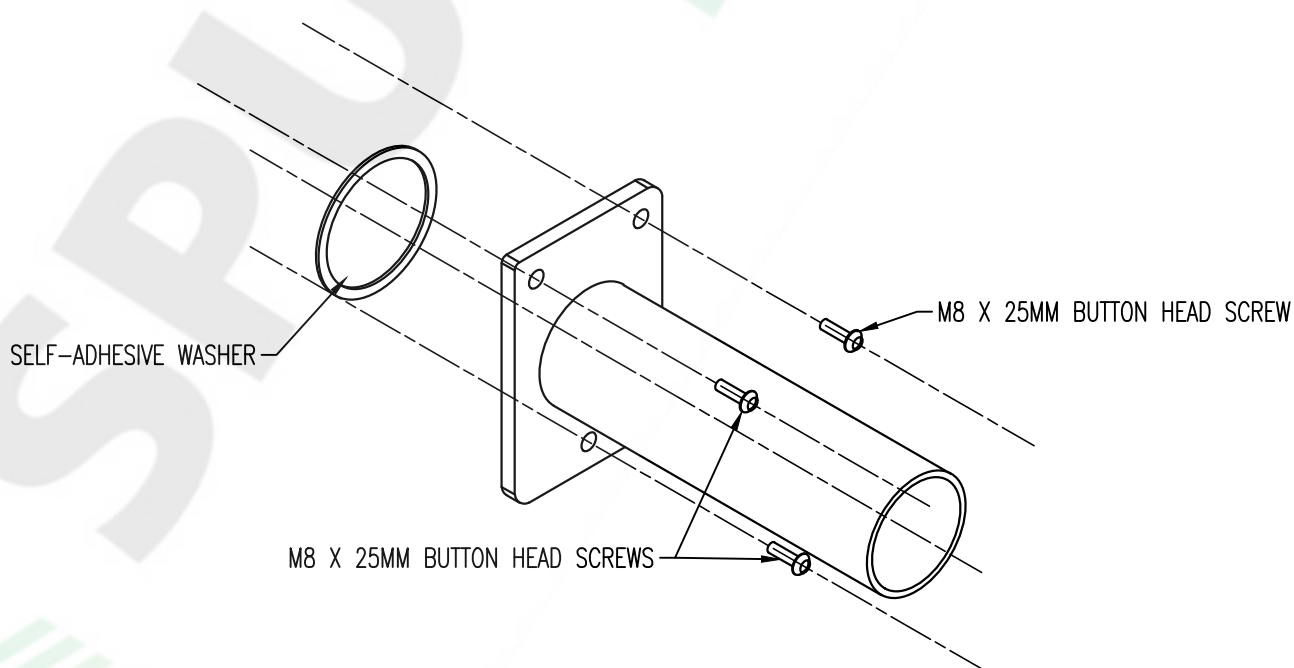

ISOMETRIC VIEW
SCALE 1:4

ESTIMATED WEIGHT = 2KG

Rev	Amendment Description	By	Chk	Date	DESIGN PARAMETERS:
1	SECOND PRODUCTION ISSUE	SG	MV	21.01.20	Design Working Life: 25 Importance Level: 1 Wind Region: A Terrain Category: 2 Site Elevation: <350m
					PRODUCT NUMBER
					SRSHSO/60200G
					DRG.SIZE
					A3
					SCALE
					AS SHOWN
					SHEET
					C1
					SHT 01/01
					REVISION
					1



www.spunlite.co.nz

PRODUCT: STANDARD RANGE

TITLE: SHS SIDE MOUNT SPIGOT 60 O.D. x 200MM

SPUNLITE POLES LTD AND OR WINDSOR URBAN LTD CLAIM AUTHORSHIP OF THIS WORK & RETAIN INTELLECTUAL & ARTISTIC COPYRIGHT