

THIS POLE IS RATED FOR A COMBINED LOADING OF 60KG WITH UP TO A 0.6m<sup>2</sup> SAIL AREA (SEE DESIGN PARAMETERS BELOW)

IF YOU REQUIRE A GREATER LOADING OR ARE OUTSIDE OF THE DESIGN PARAMETERS PLEASE CONTACT SPUNLITE POLES TO CHECK CALCULATIONS

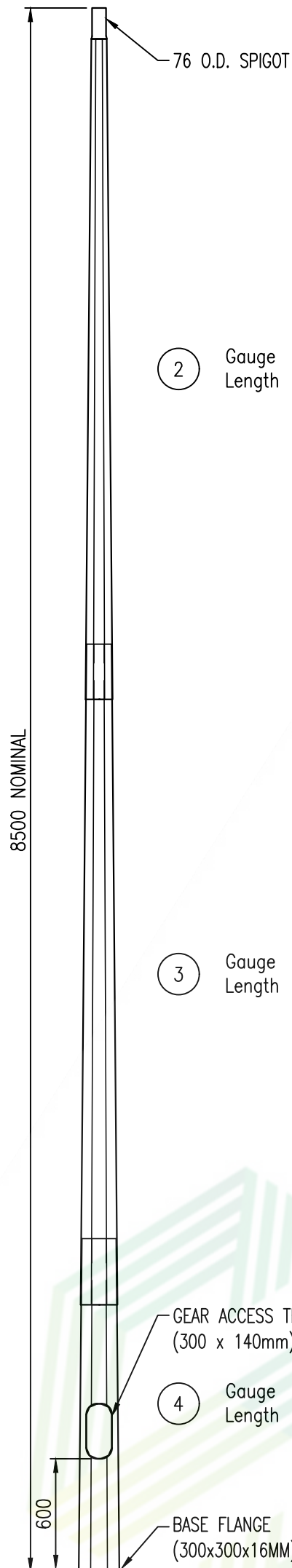

2 Gauge 2mm  
Length 3.6m

3 Gauge 2mm  
Length 3.6m

4 Gauge 2.5mm  
Length 1.8m

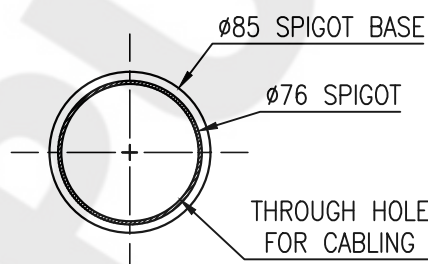

TOP MOUNTED SPIGOT PLAN VIEW  
SCALE 1:4

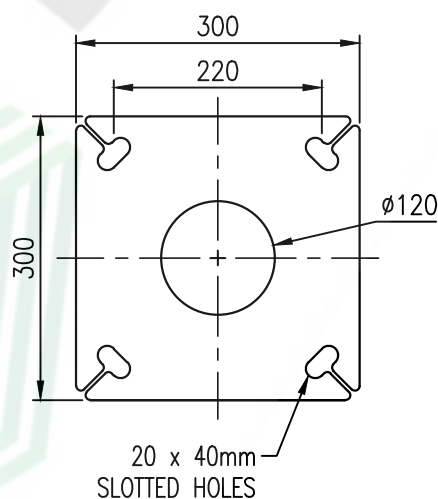

BASE FLANGE  
SCALE 1:8

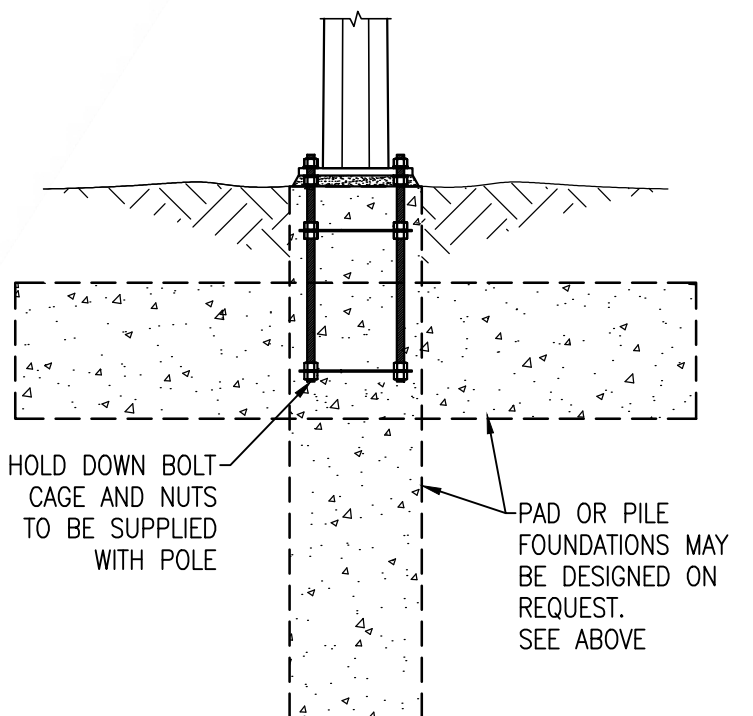

TYPICAL FLANGE-BASED FOUNDATION  
SCALE 1:20

Structural Notes

- Minimum Ultimate soil bearing pressure to be 100 kPa and Ultimate Shear Capacity of 40 kPa (a site evaluation by a qualified Civil/Geotechnical Engineer is advisable).
- Client to provide orientation and location.
- Client to provide conduit for cable entry as required.
- Contractor to check location of all services before commencing work.
- Hot dip galvanizing to AS/NZS 4680:2006 after fabrication.
- Only approved light fittings may be used, no additional attachments can be placed on pole without Spunlite's approval (maximum light size = 0.60m<sup>2</sup> with a cd = 1.0, maximum light weight = 60kg)
- All dimensions shown are nominal.

NOTE: On provision of the relevant geotechnical report, Spunlite can design specific foundations for each project. This service will incur an additional cost. Alternatively Spunlite recommends the engagement of a registered consulting engineer where upon Spunlite will supply all loadings.

COMPLETE ASSEMBLED VIEW  
SCALE 1:30

ESTIMATED WEIGHT = 89KG

Rev	Amendment Description	By	Chk	Date	DESIGN PARAMETERS:
1	SECOND PRODUCTION ISSUE	SG	DC	20.08.20	Design Working Life: 25 Importance Level: 1 Wind Region: A Terrain Category: 2 Site Elevation: <350m
					PRODUCT NUMBER SRFF/08G SHEET C1 SHT 01/01
PRODUCT: STANDARD RANGE TITLE: NOMINAL 8.5M OCTAGONAL FLOODLIGHTING POLE FLANGE BASED W/ 76 O.D. SPIGOT					DRG.SIZE: A3 SCALE: AS SHOWN REVISION: 1
SPUNLITE POLES LTD AND OR WINDSOR URBAN LTD CLAIM AUTHORSHIP OF THIS WORK & RETAIN INTELLECTUAL & ARTISTIC COPYRIGHT					