

HOLD DOWN BOLT CAGE ASSEMBLY FOR USE WITH FLANGE BASED POLES @ 220 CENTRES

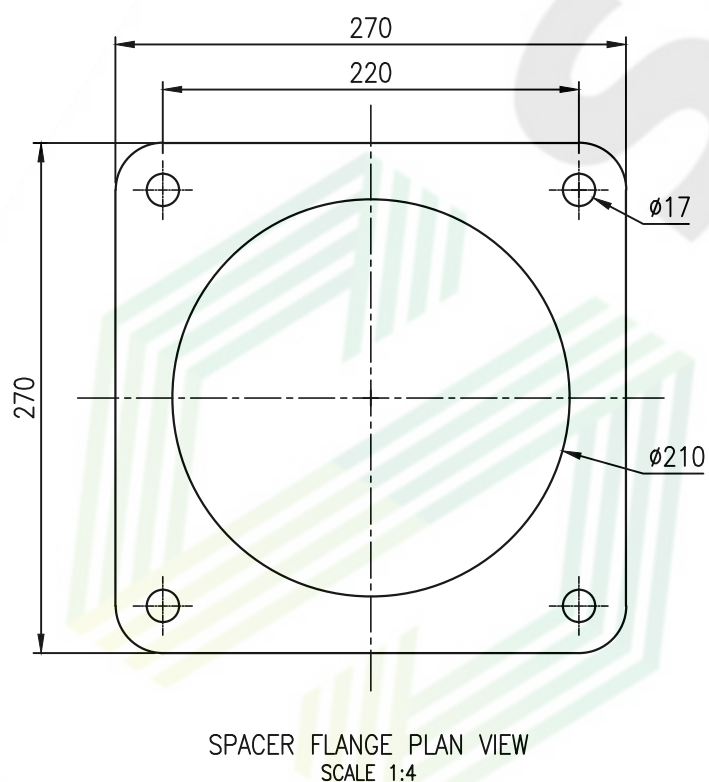
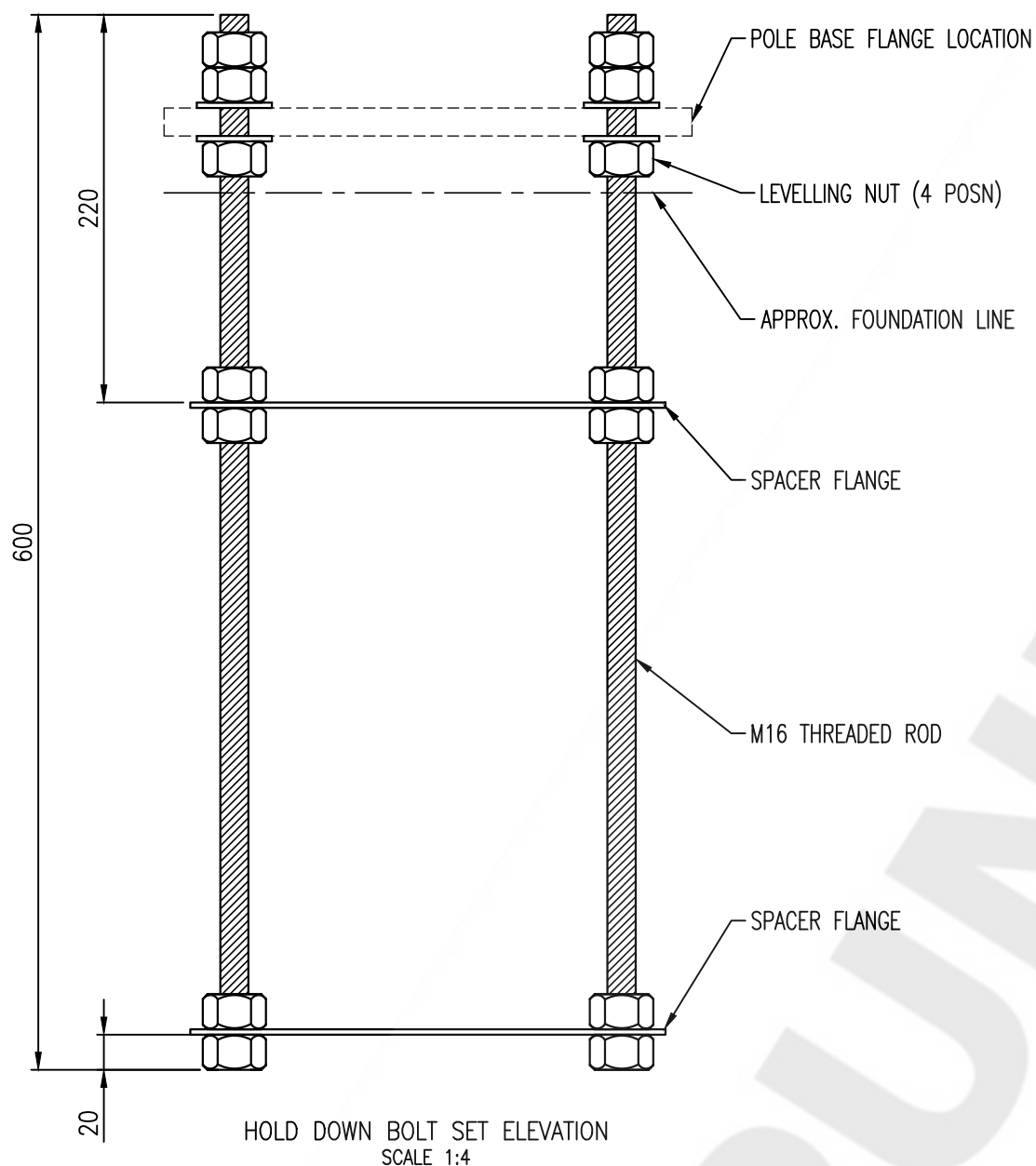

Notes

- Bottom nuts (Levelling Nuts) to sit just above wet concrete on installation.
- Bottom nuts to be dumpy levelled before pole is placed on foundations.
- Locating templates intended to remain in place after installation.
- Erect pole and tighten nuts "Snug Tight" as prescribed in NZS 3404:1:2009 Clause 4.2.6.2 (A).
- Compact dry-pack mortar between base flange and foundation surface. Material to provide 1 day strength of 20 MPa and 20 day strength of 55 MPa. Install drainage tubes.
- Additional information available at www.spunlite.co.nz

Parts List (for complete set)

- 2 x 270mm/sq 3ms spacer flange (MTP/0424)
- 28 x M16 Grade 8.8 galv nuts (FNUT/1000)
- 8 x M16 Grade 8.8 galv washers (FSH/4010)
- 4 x M16 x 600mm Grade 8.8 Galv threaded rods (FTRD/1030). Trim from 1000mm and locate cut ends to base. Remediate corrosion protection with high solids zinc primer.

ESTIMATED WEIGHT = 6.2KG

Rev	Amendment Description	By	Chk	Date	DESIGN PARAMETERS:	
1	SECOND PRODUCTION ISSUE	SG	MV	21.01.20	Design Working Life: 25 Importance Level: 1 Wind Region: A Terrain Category: 2 Site Elevation: <350m	
SPUNLITE LIMITED <small>www.spunlite.co.nz</small>					PRODUCT NUMBER SOAR/0629	SHEET C1 SHT 01/01
					TITLE: HOLD DOWN BOLT CAGE ASSEMBLY G8.8 M16 X 600MM (220 CENTRES)	DRG.SIZE A3
SPUNLITE POLES LTD AND OR WINDSOR URBAN LTD CLAIM AUTHORSHIP OF THIS WORK & RETAIN INTELLECTUAL & ARTISTIC COPYRIGHT						