

HOLD DOWN BOLT CAGE ASSEMBLY FOR USE WITH FLANGE BASED POLES @ 160 CENTRES

IF YOU REQUIRE A GREATER LOADING OR ARE OUTSIDE OF THE DESIGN PARAMETERS PLEASE CONTACT SPUNLITE POLES TO CHECK CALCULATIONS

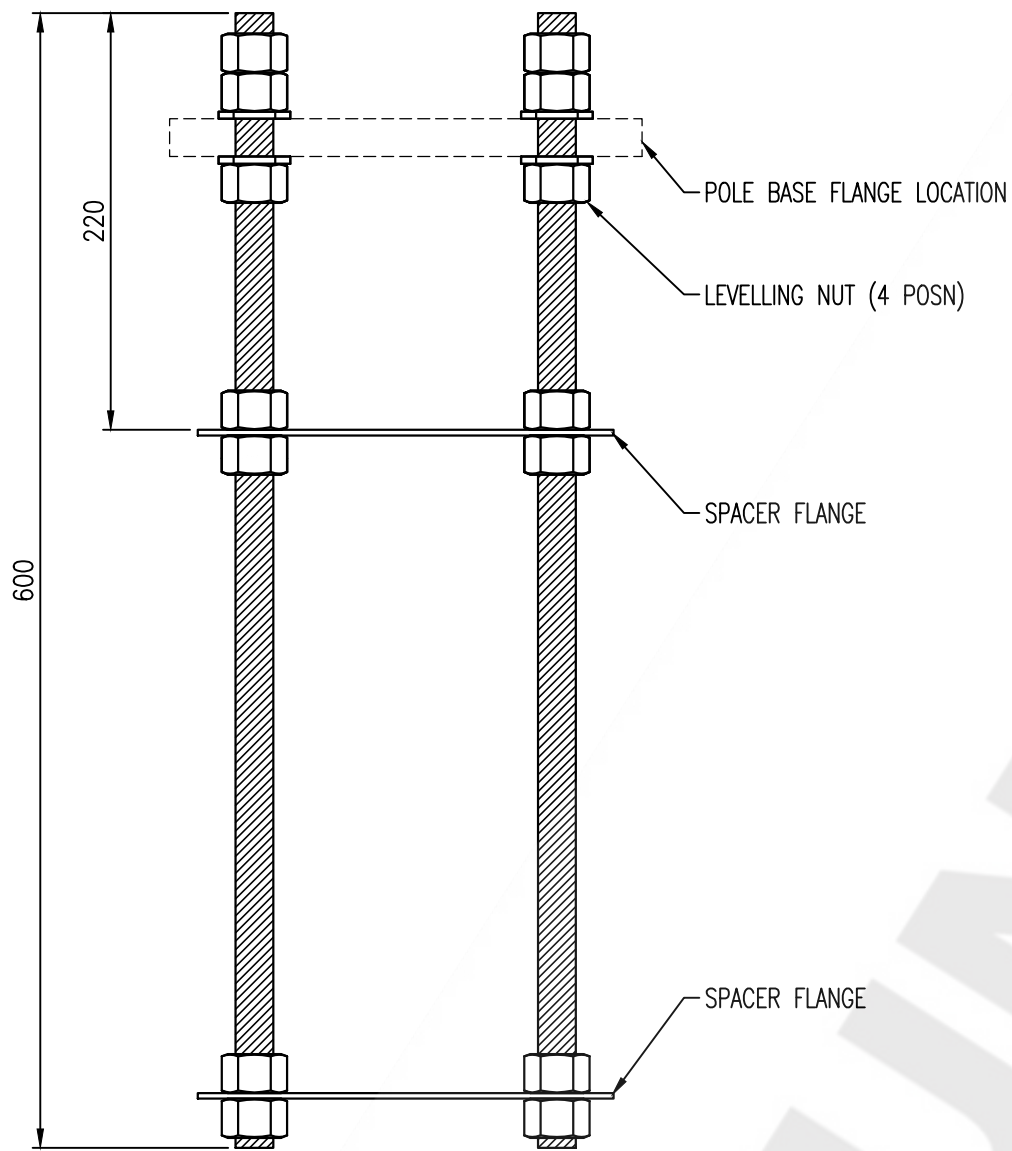

HOLD DOWN BOLT SET ELEVATION
SCALE 1:4

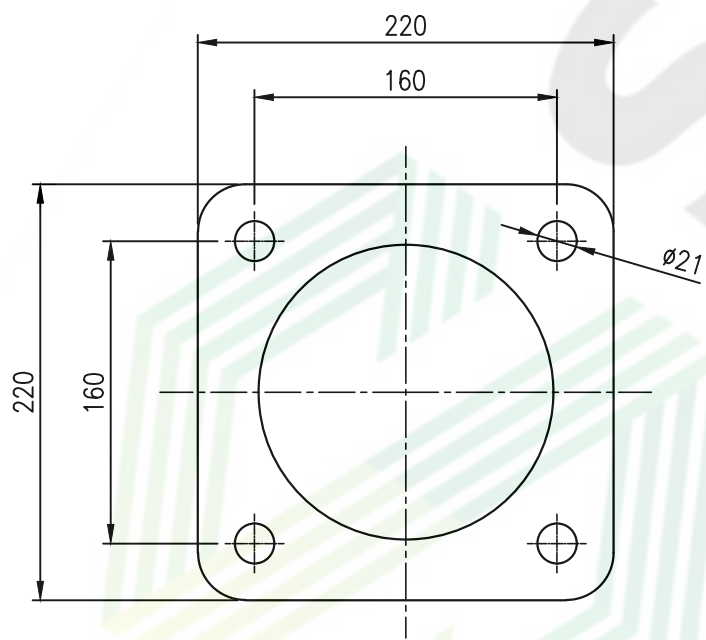

SPACER FLANGE PLAN VIEW
SCALE 1:4

Notes

- Bottom nuts (Levelling Nuts) to sit just above wet concrete on installation.
- Bottom nuts to be dumpy levelled before pole is placed on foundations.
- Locating templates intended to remain in place after installation.
- Erect pole and tighten nuts "Snug Tight" as prescribed in NZS 3404:1:2009 Clause 4.2.6.2 (A).
- Compact dry-pack mortar between base flange and foundation surface. Material to provide 1 day strength of 20 MPa and 20 day strength of 55 MPa. Install drainage tubes.
- Additional information available at www.spunlite.co.nz

ESTIMATED WEIGHT = 9KG

Rev	Amendment Description	By	Chk	Date	DESIGN PARAMETERS:												
1	SECOND PRODUCTION ISSUE	SG	MV	21.01.20	Design Working Life: 25 Importance Level: 1 Wind Region: A Terrain Category: 2 Site Elevation: <350m												
					<table border="1" style="width: 100%; border-collapse: collapse;"> <tr> <td style="width: 30%;">PRODUCT NUMBER</td> <td style="width: 70%;">SHEET</td> </tr> <tr> <td>SOAR/0626</td> <td>C1</td> </tr> <tr> <td>DRG.SIZE</td> <td>SCALE</td> </tr> <tr> <td>A3</td> <td>AS SHOWN</td> </tr> <tr> <td></td> <td>REVISION</td> </tr> <tr> <td></td> <td>1</td> </tr> </table>	PRODUCT NUMBER	SHEET	SOAR/0626	C1	DRG.SIZE	SCALE	A3	AS SHOWN		REVISION		1
PRODUCT NUMBER	SHEET																
SOAR/0626	C1																
DRG.SIZE	SCALE																
A3	AS SHOWN																
	REVISION																
	1																
		PRODUCT: STANDARD RANGE			PRODUCT NUMBER SOAR/0626												
TITLE: HOLD DOWN BOLT CAGE ASSEMBLY G8.8 M20 X 600MM @ 160 CENTRES		DRG.SIZE: A3			SCALE: AS SHOWN												
SPUNLITE POLES LTD AND OR WINDSOR URBAN LTD CLAIM AUTHORSHIP OF THIS WORK & RETAIN INTELLECTUAL & ARTISTIC COPYRIGHT																	